



PREMIER GRILLS & ACCESSORIES





BUILT-IN PREMIER GRILLS

Standard Grill Features:

- LED Control Panel Lights
- Direct Heat & Ceramic Radiant Grilling System
- 18 Gauge Stainless Steel U-Burners
- Interior Halogen Light(s)
- Welded Construction
- Mirror Polished Accents
- Double Lined Hood
- Temperature Gauge
- 9V Electronic Ignition
- Warming / Cooking Rack



DHBQ38R-B
DHBQ38RS-B

38" OUTDOOR GAS GRILL *with IR Rotisserie*
38" OUTDOOR GAS GRILL *with Sear Zone and IR Rotisserie*

- Three 18 gauge stainless steel U-burners
- Integrated infrared rotisserie burner
- Two position rotisserie with heavy duty stainless steel motor (40 lb. capacity)
- 625 sq. in. grilling space
- 210 sq. in. warming rack

Delta Heat grills and accessories

add convenience and performance to your outdoor kitchen, while enhancing the experience of your backyard gatherings. Elegance and unmistakable quality will ensure years of enjoyment for you, your family and friends.

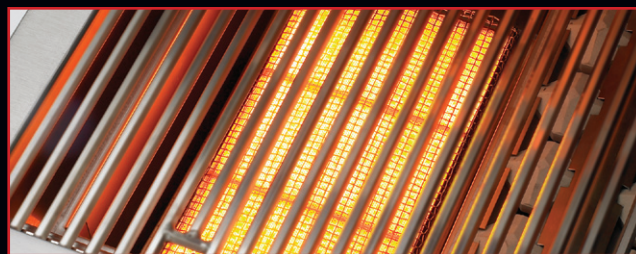

Sear Zone

Intense direct heat will sear your meats faster and deeper to seal in more juices. More juices means moist, more flavorful food. All 32" and 38" grills are available with or without a Sear Zone. A kit (sold separately) is available for the 26" grill (Kit Model: DHSZ-KIT-B).



Rotisserie

An integrated rotisserie with infrared (IR) back burner is standard on 38" grills. 32" grills are available with or without an integrated rotisserie. 26" grills are non-rotisserie only. A rotisserie kit (sold separately) is available for all non-rotisserie grills (Kit model: DHRS-KIT).



DHBQ32R-B | 32" OUTDOOR GAS GRILL *with IR Rotisserie*
DHBQ32RS-B | 32" OUTDOOR GAS GRILL *with Sear Zone and IR Rotisserie*

- Three 18 gauge stainless steel U-burners
- Integrated infrared rotisserie burner
- Two position rotisserie with heavy duty stainless steel motor (40 lb. capacity)
- 525 sq. in. grilling space
- 174 sq. in. warming rack

*Non-rotisserie model available (model: **DHBQ32G-B**)*

DHBQ26G-B | 26" OUTDOOR GAS GRILL

- Two 18 gauge stainless steel U-burners
- 420 sq. in. grilling space
- 139 sq. in. warming rack
- Optional sear zone kit (Model DHSZ-KIT-B)

*Optional rotisserie kit sold separately
(Kit model: DHRS-KIT)*

OUTDOOR ACCESSORIES



DHSB1D-B | SINGLE SIDE BURNER, DROP-IN

- Drop-in model
- Stainless steel construction
- 16,000 BTU sealed burner
- Battery powered electronic ignition
- Stainless steel top cover



DHSB2-B | DOUBLE SIDE BURNER

- LED control panel lights
- Stainless steel construction
- Two 16,000 BTU sealed burners
- 9V electronic ignition
- Stainless steel top cover

ACCESS DOORS & STORAGE DRAWERS



(DHAD22R-C shown)



(DHAD18L-C shown)



(DHAD32-C shown)

DHAD22(L/R)-C | ACCESS DOOR

- Horizontal orientation (22" x 16 1/4")
- Stainless steel construction
- One-piece 18 gauge frame
- Adjustable European hinges
- Available left or right hinged (must specify)

DHAD-C | SINGLE ACCESS DOOR

- Stainless steel construction
- One-piece 18 gauge frame
- Adjustable European hinges
- Available left or right hinged (must specify)

Three sizes available:

DHAD16(L/R)-C 16" Wide Access Door
(Note: DHAD16(L/R)-C is 22 1/4" High)

DHAD18(L/R)-C 18" Wide Access Door
DHAD24(L/R)-C 24" Wide Access Door

DHAD-C | DOUBLE ACCESS DOORS

- Stainless steel construction
- Adjustable European hinges
- One-piece 18 gauge frame

Six sizes available:

DHAD26-C 26" Wide Double Access Doors
DHAD30-C 30" Wide Double Access Doors
DHAD32-C 32" Wide Double Access Doors
DHAD36-C 36" Wide Double Access Doors
DHAD38-C 38" Wide Double Access Doors
DHAD42-C 42" Wide Double Access Doors



DHTD18-B | TRASH / LP TANK DRAWER

- Full extension heavy duty drawer slides
- Stainless steel construction
- One-piece 18 gauge frame
- Adjustable brackets to fit a standard size trash container or LP tank (*Trash container and LP tank not included*)



DHTD18T-B | TALL TRASH DRAWER

- Full extension heavy duty drawer slides
- Stainless steel construction
- One-piece 18 gauge frame
- Holds larger capacity trash container (container included)
- Full pull out drawer for increased stability



DHTC | TRASH CHUTE

- Removable sliding cutting board
- Angled side wall directs waste toward container below
- Stainless steel cover included
- Aligns over the built-in trash drawer (*Trash drawer sold separately*)



DHSD132-B | 13" DOUBLE STORAGE DRAWERS

- Stainless steel construction
- One-piece 18 gauge frame
- Full extension heavy duty drawer slides
- Two (2) extended depth drawers



DHSD133-B | 13" TRIPLE STORAGE DRAWERS

- Stainless steel construction
- One-piece 18 gauge frame
- Full extension heavy duty drawer slides
- Three (3) extended depth drawers



(DHDD302-B shown)

DHDD-B | DOOR / TWO OR THREE DRAWER COMBO

- Stainless steel construction
- One-piece 18 gauge frame
- Adjustable European hinges
- Full extension heavy duty drawer slides
- Two (2) or three (3) extended depth drawers

Four models available:

- DHDD302-B** 30" Wide Door & Two (2) Drawer Combo
- DHDD303-B** 30" Wide Door & Three (3) Drawer Combo
- DHDD362-B** 36" Wide Door & Two (2) Drawer Combo
- DHDD363-B** 36" Wide Door & Three (3) Drawer Combo



DHOR20 | 20" OUTDOOR REFRIGERATOR

- Stainless steel exterior
- Reversible door (left or right hinged)
- Locking door
- UL approved for outdoor use
- Front venting for under counter installation
- 4.1 cubic feet of storage space
- Three adjustable wire shelves
- Drink can holder plus 3 shelves in the door
- Adjustable leveling legs
- 110 volts / 115 watts

Note: Unit is sourced from a leading refrigeration company outside the USA



DHOC15D | 15" DROP-IN COOLER

- Seamless welded construction
- Insulated lid with gasket seal
- 20" depth for increased capacity
- Brass drain with plug
- Heavy duty hinges
- Removable lid



DHCD30-B | 30" COOLER DRAWER

- Full extension heavy duty drawer slides
- Stainless steel construction
- Can accommodate up to a 50 quart cooler without casters
- Maximum cooler dimensions are: 13.5"H x 25"W x 14"D (Cooler not included)



DHOS15 | 15" DROP-IN SINK

- Seamless welded construction
- Large basin accommodates oversized items
- 2-inch stainless steel basket drain
- Includes cold faucet



DHPT15-B | 15" PAPER TOWEL HOLDER

- Stainless steel construction
- One-piece 18 gauge frame
- Swing down paper towel compartment
- Holds a standard size paper towel roll



VCBQ | VINYL COVERS

- Available for all built-in and freestanding grill models
- Features durable vinyl to protect the stainless steel finish



FREESTANDING PREMIER GRILLS

A Delta Heat Premier Grill on a base brings a touch of outdoor lifestyle to any patio or deck. These grill bases are designed with utility and longevity in mind. Make the most of your outdoor space with one of these three models.

Grill Base Features:

- Four heavy duty casters (two locking)
- Two stationary side shelves with integrated utensil hooks
- Grill head & access doors can be removed for built-in application (38" & 32" grill bases)
- Front access doors (38" & 32" grill bases)
- Rear LP tank loading (26" pedestal base only)



DHGB38-B 38" GRILL BASE



DHGB32-B 32" GRILL BASE



DHPB26-B 26" GRILL BASE

CUTOUT DIMENSIONS

Allow minimum of 3" clearance from the grill's rear edge (3.75" from cutout) to the backsplash to allow hood to fully open.

Rotisserie Motor can be installed either on the right hand side or left hand side.

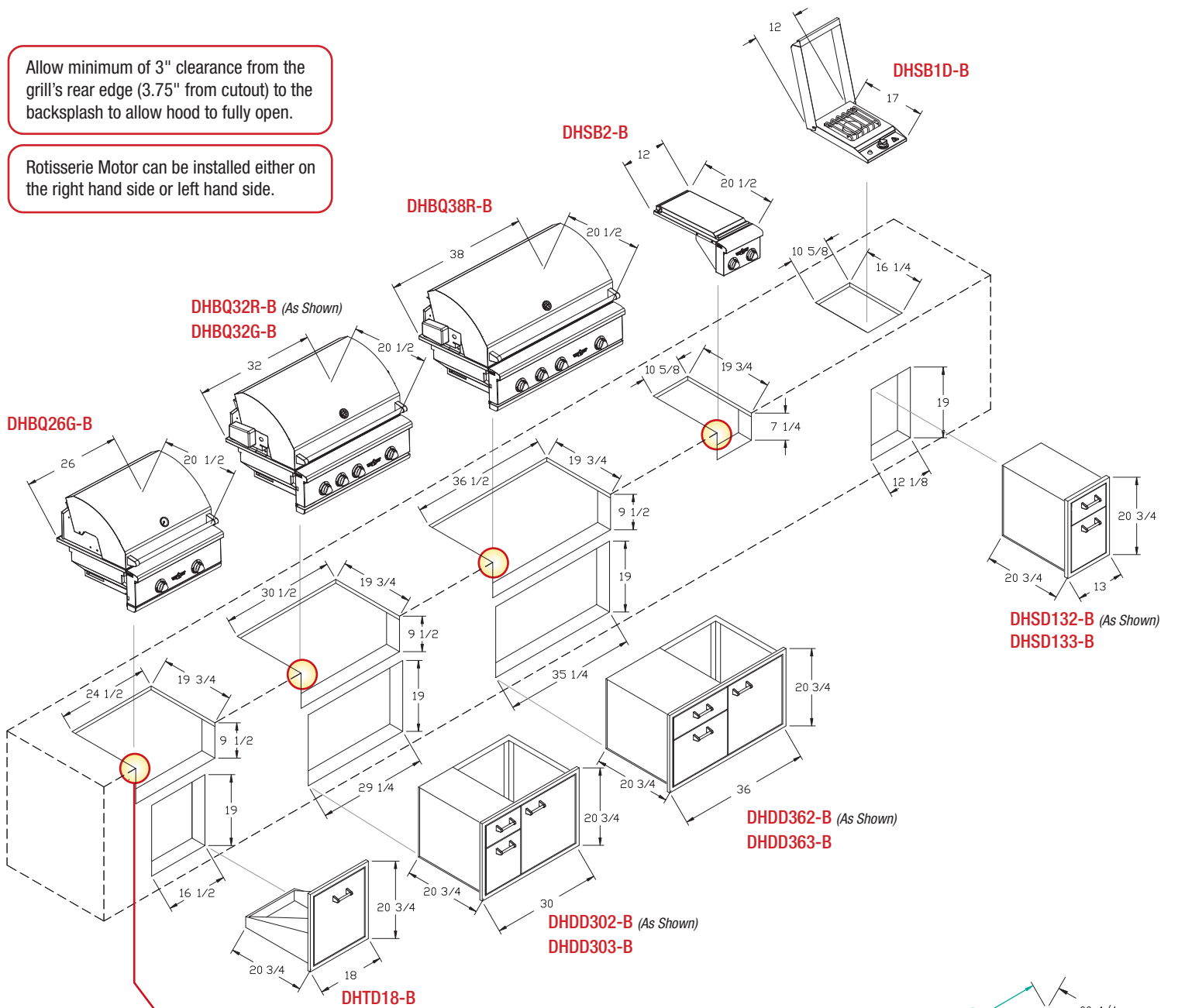

DETAIL

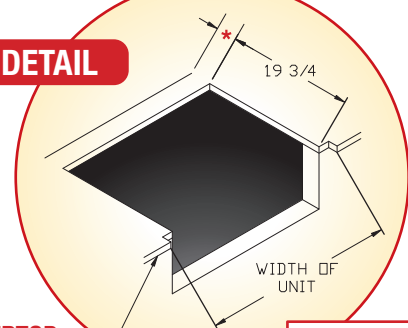

COUNTERTOP OVERHANG

Note: Required to ensure a flush fit of all grills and the double side burner.

* Add 3.75" to allow for hood opening

INSULATING JACKETS

- Stainless steel construction
- Polished stainless steel trim
- For installation in combustible construction

MODEL	A	B
DHIJ26	30 7/8	29
DHIJ32	36 7/8	35
DHIJ38	42 7/8	41

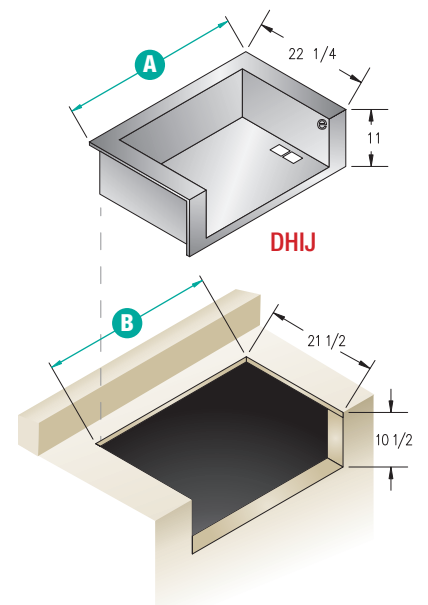

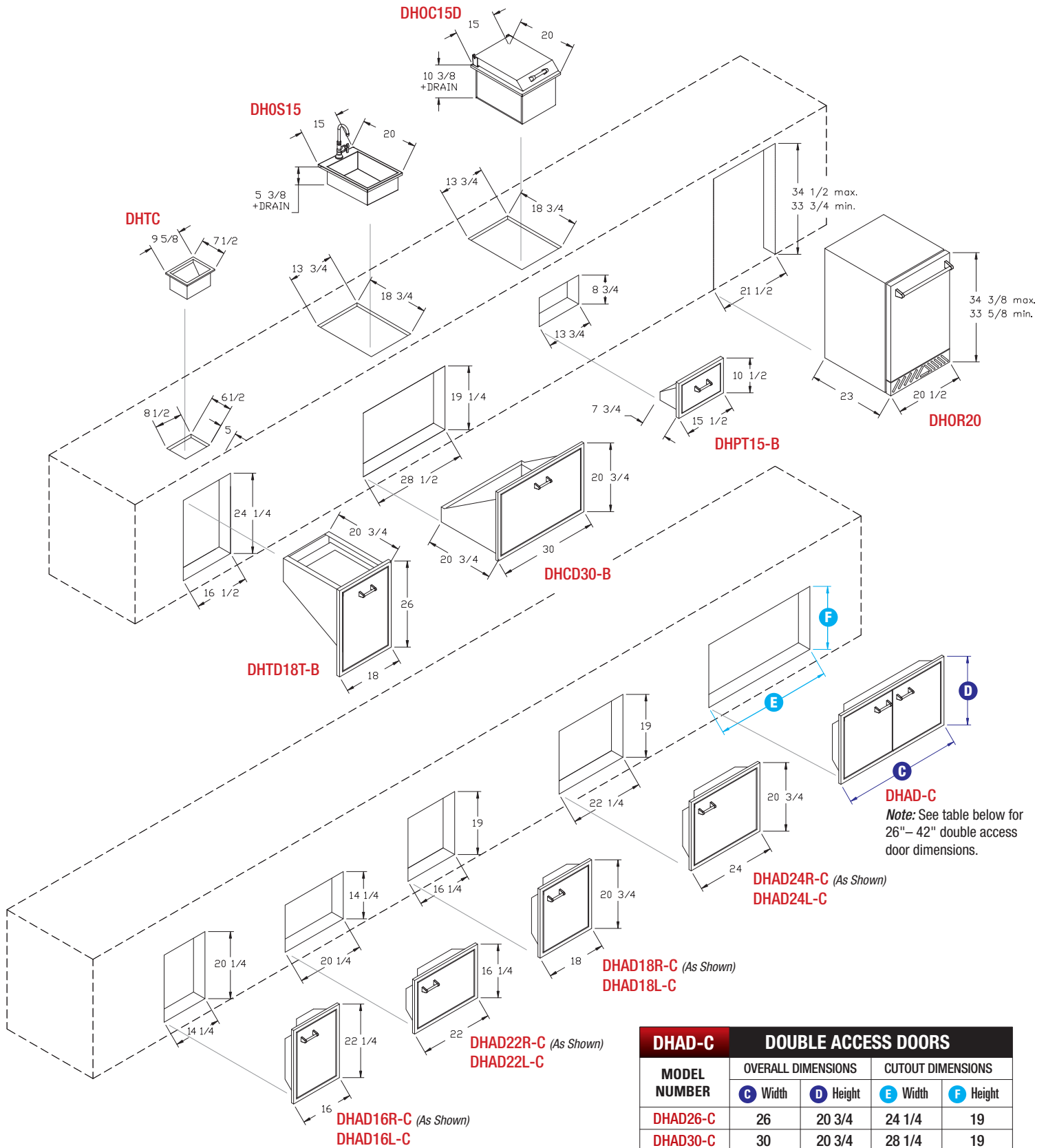

DHAD-C MODEL NUMBER	OVERALL DIMENSIONS		CUTOUT DIMENSIONS	
	C Width	D Height	E Width	F Height
DHAD26-C	26	20 3/4	24 1/4	19
DHAD30-C	30	20 3/4	28 1/4	19
DHAD32-C	32	20 3/4	30 1/4	19
DHAD36-C	36	20 3/4	34 1/4	19
DHAD38-C	38	20 3/4	36 1/4	19
DHAD42-C	42	20 3/4	40 1/4	19

(Effective: January 2014)

For the constant advancement of our products, Delta Heat® reserves the right to change the specifications, designs, and materials of the products without prior notification.



Delta Heat products are engineered, designed and manufactured by the industry leading premium grill and outdoor kitchen equipment experts – Twin Eagles, Inc.

Creative design, innovative engineering, precision manufacturing, and impeccable quality control – all under one roof!

Twin Eagles develops, from design prototyping to testing to final production, gas grills and outdoor kitchen accessories at their state-of-the-art company owned facility in Cerritos, California. The Twin Eagles family consists of passionate, highly trained designers, engineers and skilled craftsmen.



Designed and manufactured by



DELTA HEAT®

13259 East 166th Street, Cerritos, CA 90703

(800) 422-0091

www.deltaheat.com

© 2014 Delta Heat. All rights reserved. P/N 18619B 01/14
For the constant advancement of our products, Delta Heat® reserves the right to change the specifications, designs, and materials of the products without prior notification.



MADE IN THE U.S.A.