



Defining the Art of Outdoor Cooking







Twin Eagles founder, owner and operator is award-winning Gas Engineer, Dante Cantal.

For more than 30 years, Dante has been instrumental in the development and evolution of commercial and residential cooking equipment.

Dante started his career in 1977, designing residential appliances for White Westinghouse and General Electric. Over the following 20 years, Dante directed the design team at leading restaurant equipment companies, U.S. Range and Jade Range, where he designed commercial cooking equipment for major restaurants and hotels. Many of these designs are still in use today.

Dante's expert knowledge of residential appliances and high-performance, commercial cooking equipment, set the stage for his transition to premium grills and outdoor kitchen equipment when he co-founded Lynx in 1996.

In the late 1990's the premium grill and outdoor kitchen trend were growing rapidly. Dante immediately saw an opportunity to use his

Who is TWIN EAGLES?

expertise to design grills and outdoor kitchen equipment for several major brands including Dynasty, Maytag, Jenn-Air and Ducane to name a few.

In 2005, Dante introduced the Twin Eagles line of products – a true culmination of past experiences, refined and perfected to ensure exceptional design, construction and performance.

Creative design, handcrafted construction and professional performance have long been the characteristics that have made Dante a leader in the premium grill and outdoor kitchen industry. These traits are the foundation for the Twin Eagles line of products.

Although Twin Eagles style is truly unique and each product is constructed to exacting standards, the performance of the grilling system is what separates Twin Eagles from other premium grill brands.

*We invite You to
Experience the Difference.*



TWIN EAGLES *Style*

Stylish outdoor kitchens are the latest trend in entertaining. Choosing the right grill and accessories for your perfect backyard entertainment center is important. It's your personal touch to your outdoor kitchen, a reflection of your lifestyle.

Twin Eagles design is truly unique, with exclusive geometric shapes, contoured angles, seamless welds and hi-polished accents. Every grill is an intriguing blend of modern design and classic elegance, making them a perfect match for both traditional and contemporary architecture.





TWIN EAGLES *Performance*

The performance of the exclusive grilling system is what separates Twin Eagles from other premium grill brands.

Mixing direct heat from specifically placed ports and channels with radiant heat from ceramic briquettes allows your grill to reach higher temperatures and distribute heat evenly to the grates. Your grill will preheat faster, perform better and use less gas. Hexagonal grates retain and conduct more heat into your food and provide more food-to-surface contact to brand your food with thick restaurant style sear marks.

Drafting vents draw cool air from the bottom of the firebox keeping the heat above the burners where it is needed while keeping the air/gas mixture constant for a more efficient flame. Zone dividers enable you to grill effectively with one burner only or regulate each area at a different temperature when cooking different food items.

This highly engineered grilling system will elevate your next outdoor grilling experience to new levels of performance.





TWIN EAGLES *Quality*

Quality you will immediately see, feel and trust. The latest laser cutting technology allows Twin Eagles to create the precise geometric shapes unique to its signature styling. The use of high grade 300 series stainless steel and seamless heli-arc welded construction provides tremendous strength and durability essential for outdoor use.

Quality control is assured throughout every step of the manufacturing process. This guarantees superior craftsmanship that will withstand and endure the harsh elements of the outdoors and bring you and your family endless enjoyment.



Premium Grill Features



Hexagonal Grates

Our grills feature 3/8" stainless steel hexagonal grates which retain more heat, enabling more heat contact to food for even cooking. Plus, these grates generate deep, dark, professional restaurant-style sear marks.



Grill Hood Assist System

Concealed heavy duty extension springs allow for easy opening and closing of the hood by reducing the weight load.



Zone Dividers

Each 25,000 BTU burner is contained to control heat independently from one area to another. You will be able to maintain each zone with a different temperature or effectively cook with only one burner operating.



Grill Lights

Two halogen lights illuminate the cooking surface. Advantageous for the evening barbecue, eliminating the need for external lights that may disrupt the ambience of your gathering.



Grill Light Switch

Additional switch automatically turns interior lights off when the grill hood is down to add longer life to your lights.



LED Lights & Polished Accents

Decorative blue lights illuminate the control knobs turning your grill into the main attraction, even when not in use. The exquisite hi-polished accents add luxurious refinements to your grill and accessories.



Hot Surface Ignition

Lighting the gas burners and the rear rotisserie burner just got easier with electric hot surface ignitors. The more reliable ignitors operate by pushing in the burner or rotisserie control knob.



Smoker Box

Enhance the flavor of your food. Sealed Smoker Box holds liquid for soaking hickory, mesquite, or your favorite woodchips to give foods a smokey flavor.

BUILT-IN PREMIUM GRILLS

Standard Grill Features

- 25,000 BTUs per burner, constructed with 14 gauge 304 stainless steel with lifetime warranty
- High quality ceramic briquettes
- Hexagonal grates for more food-to-surface contact
- Zone dividers to regulate different temperatures
- Reliable hot surface ignition
- Easy to open hood assist system
- Interior lights with hood activated light switch for nighttime grilling
- Decorative LED control panel lights
- Multi-position and stow away warming rack
- Large capacity smoker box
- Temperature gauge



TEBQ30G-B | 30" Outdoor Gas Grill

TEBQ30R-B | 30" Gas Grill with Infrared Rotisserie

TEBQ30RS-B | 30" Gas Grill with Infrared Rotisserie and Sear Zone



TEBQ36R-B | 36" Outdoor Gas Grill *with IR Rotisserie*

TEBQ36G-B | 36" Gas Grill

TEBQ36RS-B | 36" Gas Grill with Infrared Rotisserie and Sear Zone



TEBQ42R-B | 42" Outdoor Gas Grill *with IR Rotisserie*

TEBQ42G-B 42" Gas Grill

TEBQ42RS-B 42" Gas Grill with Infrared Rotisserie and Sear Zone



Sear Zone

All 30", 36" and 42" grills are available with or without Sear Zone (standard on 54" grill). 25,000 BTUs of Direct Heat will sear your meats faster and deeper to seal in more juices. More juices means moist, more flavorful food.



Infrared Rotisserie

All grills are available with an infrared rear rotisserie burner and rotisserie set which includes spit rod, meat forks, and porcelain basting pan. Two position system maintains proper distance from the infrared burner to control efficient browning and to contain more juices. Rotisserie motor has 100 lb. turning capacity.



BUILT-IN PREMIUM GRILLS



TEBQ54RS-B | 54" Outdoor Gas Grill *with IR Rotisserie*

TEBQ54RS-B 54" Gas Grill with Sear Zone and two independently controlled Infrared Rotisserie burners

Charcoal Grill



TECG30-B | **30" Outdoor Charcoal Grill**

TECG30-B 30" Charcoal Grill with adjustable charcoal tray and air/temperature control louvers



Air/temperature control louvers



Easy charcoal access front door

Charcoal Grill Features

- Seamless welds and signature hi-polished accents
- Double lined hood (front and sides)
- Temperature gauge
- Warming/cooking rack
- Adjustable charcoal tray

BUILT-IN ACCESSORIES



TESB131-B
TESB132-B | Side Burners

Side Burners add tremendous versatility to your outdoor kitchen. Whether you need to boil, stir fry, saute or simmer, the 17,500 BTU dual ring European sealed burner(s) is ready to deliver the heat you need. The one piece stainless steel "S" grate allows for easy maneuverability of pots and pans between burners.

- Available with single burner (TESB131-B) or double burner (TESB132-B)
- Wind guard
- Stainless steel cover included
- LED control panel lights



TEBC30-B | Dine & Breakfast Club

A great companion to your grill, our innovative Dine & Breakfast Club is perfect for family breakfast outside, or complement your evening barbecue with grilled shrimp, scallops, chicken or sauteed vegetables.

Griddle:

- Stainless steel, solid 1/4" thick griddle surface
- Thermostat control with heat on indicator light
- Hot surface ignition with safety gas valve
- 20,000 BTU stainless steel griddle burner
- 120 V electrical power cord supplied

Side Burner:

- Stainless steel, "S" grates to easily slide pots and pans
- Two (2) 17,500 BTU dual ring European sealed burners
- Electronic ignition
- Stainless steel cover included
- LED control panel lights

Outdoor kitchen griddles — another pioneering innovation from Twin Eagles.



TETG30-B | Teppanyaki Griddle

Our unique Teppanyaki Griddle is the perfect complement to your outdoor kitchen. Use it anytime of day, cook pancakes and eggs for breakfast, grilled cheese sandwiches for lunch, or an evening of boneless chicken and stir fried vegetables. And clean up is easy.

- Stainless steel, solid 5/16" thick griddle surface
- Two independent thermostatically controlled gas burners
- Total of 40,000 BTUs
- Heat ON indicator lights
- Hot surface ignition with safety gas valve
- 120 V electrical power cord supplied
- Stainless steel cover included
- LED control panel lights

Power Burner



(TEPB24HG-B shown)

TEPB24-B TEPB24HG-B

24" POWER BURNER

Twin Eagles oversized cast brass, 2-ring burner is the most powerful residential Power Burner, reaching 70,000 BTUs. The reversible commercial cooking grate on Model TEPB24HG-B is constructed of 8 mm stainless steel welded plates.

- Reversible grate for restaurant stock pots and commercial woks (model TEPB24HG-B)
- All stainless steel commercial design cooking grate made of welded plates (model TEPB24HG-B)
- Powerful 70,000 BTU burner with low simmer
- Over-sized cast brass 2-ring burner
- Reliable hot surface ignition
- One piece front panel with decorative LED lighting
- Traditional bar grate model available (TEPB24-B)
- Stainless steel cover included

Warming Drawers



TEWD30-B | 30" Warming Drawer

Keep food warm and ready to serve with our 30" warming drawer. Ideal for holding lasagna and casserole trays, keeping bread warm, or placing dishes inside until it's time to eat. Humidity management controls moisture inside the drawer, keeping food from drying out. Warming drawers can also be used for defrosting food and warming towels.

- Four (4) steam pans that are specifically designed for steam or dry warming
- Concealed thermostat control
- Heat fluctuation from 60° to 220° F (15° to 104° C)
- 120 V electrical cord included
- Approved for indoor and outdoor use



TEWD42C-B | 42" Warming Drawer Combo

You get all the great features of our versatile warming drawer plus the benefit of additional storage. This deluxe combination includes a warming drawer with a practical oversized storage drawer and slide out trash holder (or LP tank holder).

- 2.1 cu. ft. storage drawer
- Four (4) steam pans that are specifically designed for steam or dry warming
- Heat fluctuation from 60° to 220° F (15° to 104° C)
- Concealed thermostat control
- 120 V electrical cord included

Salamangrill



TESG24 | Salamangrill

Upgrade your outdoor kitchen to include the revolutionary design of our patented Salamangrill which cooks with a gas infrared burner mounted over the cooking grid. The burner generates 1,700 degrees of heat at the burner surface in 90 seconds. This unique cooking style retains juices and flavor without flare ups.

- Four (4) level position carriage cooks:
 - Pizza in 4 minutes
 - 1 1/2" thick steaks in 6 minutes
 - Fish in 6 minutes
 - Chicken in 6-8 minutes
- 15,000 BTU infrared burner
- Cooking grate rolls in and out, making food placement easy
- 13" Pizza stone included
- Custom vinyl cover included



Outdoor Entertainment

TEOB30-B | 30" Outdoor Bar

What backyard sanctuary is complete without an outdoor bar? Our 30" bar includes an insulated ice compartment that holds up to 40 lbs of ice. Three specially designed compartments keep beverages cool and condiments fresh.

- Stainless steel sliding ice bin cover
- Front speed rail holds 1-liter bottles
- Stainless steel bottle opener and towel ring
- Stainless steel bar sink and chrome faucet

TEMC18 | 18" Margarita Center

A versatile addition to your outdoor kitchen, the Margarita Center adds a dedicated appliance station to create a cocktail mixing center, a coffee & espresso bar, or a fresh juice bar. With the built-in GFCI (120 V) electrical outlet, just add your desired appliance and the possibilities are endless. (Blender not included)

BUILT-IN BAR ACCESSORIES



TEOB18-B | 18" Outdoor Bar

Great beverage center for outdoor entertaining. Includes an insulated ice compartment that holds up to 40 lbs of ice. Three specially designed compartments keep beverages cool and condiments fresh.

- Stainless steel sliding ice bin cover
- Front speed rail holds 1-liter bottles
- Stainless steel bottle opener and towel ring



TEOS24 | 24" Drop-in Sink

Enjoy the convenience of a large, commercial quality sink in your outdoor kitchen. The oversized basin accommodates large items and the seamless welded construction enhances the beauty and durability of this outdoor kitchen essential.

- Integrated soap dispenser
- 3.5-inch stainless steel basket drain
- Includes cold faucet. Optional hot/cold available (model TEFHC-KIT)
- Optional stainless steel cover (model TEOS24-LID)



TEOC24D | 24" Drop-in Cooler

No backyard gathering is complete without ice-cold beverages. This fully insulated, premium quality drop-in cooler accommodates up to 60 bottles & 25 lbs. of ice. The insulated bin and lid with gasket seal ensures that contents stay cold.

- Seamless welds & signature hi-polished accents
- Removable / sliding condiment tray
- Removable lid with heavy duty hinges
- Brass drain with plug

BUILT-IN BAR ACCESSORIES



TEOR24-C | 24" Outdoor Refrigerator

Keep beverages, marinating meats and side dishes cold with the convenience of a refrigerator in your outdoor kitchen. Features 6.1 cubic feet of storage, two removable wire shelves and three door shelves.

- UL Listed suitable for outdoor use
- Stainless steel exterior sides, top and full wrap door
- Automatic interior light
- Full auto defrost
- Adjustable temperature range from 33 to 52 degrees F



TECD30-B | 30" Cooler Drawer

Integrate a cooler into your outdoor kitchen with our convenient cooler drawer. Provides easy access to ice, cold beverage or marinated foods.

- 48 quart ice chest included (color may vary)
- One-piece mounting frame for precision alignment
- Flush handle design with hi-polished accents



TEIM15-C | 15" Outdoor Ice Machine

A great addition to your outdoor bar, it produces up to 55 lbs. of ice per day and provides 22 lbs. of ice storage.

- UL approved for outdoor use
- Stainless steel door
- Stainless steel louvers with front in/front out airflow
- 55 lbs. daily ice production
- 22 lbs. of built-in storage capacity
- Optional drain pump available (model TEDP-KIT)



TEBK24-B | 24" Beer Dispenser / Single Tap
TEBK242-B | 24" Beer Dispenser / Twin Taps

Serve up frosty cold draft beer right from the tap! It can hold half or quarter kegs and includes the draft tower, CO2 tank and regulator.

- Indoor and Outdoor use
- Adjustable temperatures from ice cold to 52°F for dark lagers and ales



Built-in Accessories





TETD182T-B | 18" Double Trash Drawer

- Holds two larger capacity trash containers (**containers included**)
- One container for waste and a second for recycling
- Flush handle design with hi-polished accent
- Full pull out drawer for better stability (100 lbs. capacity)



TETD18T-B | 18" Trash Drawer

- Holds larger capacity trash container (**container included**)
- Flush handle design with hi-polished accent
- Full pull out drawer for better stability (100 lbs. capacity)



TEPT15SD-B | 15" Paper Towel Drawer

- Holds standard size paper towels
- Slide out paper towel drawer with towel bar
- Storage tray



TETC-B | Trash Chute

Impressive low profile trash chute aligns over the built in trash drawers (TETD18T-B or TETD182T-B) to easily dispose of bottles, trash and discard waste. Includes a sliding bamboo cutting board for food prep and a stainless steel cover which fits over the cutting board and chute to conceal when not in use.

- Removable sliding bamboo cutting board
- Convenient angled side wall directs waste toward trash container below
- Stainless steel cover included
- Aligns over the built-in trash drawers (Trash drawers sold separately)

ACCESS DOORS & STORAGE DRAWERS

Access Doors Features:

- Soft closing, three way adjustable concealed door hinges
- Double walled doors with welded inside liners
- Detailed finish welded corners
- One-piece mounting frame for precision alignment
- Flush handle design with hi-polished accents

Storage Drawers Features:

- Self latching, and 100 lbs. capacity, full extension slides
- Extra deep drawers for oversized utensils
- Superior welding and finish
- One-piece front frame for precision alignment
- Flush handle design with hi-polished accents



TESD301-B | 30" Large Capacity Drawer



TESD241-B | 24" Utensil Storage Drawer



TEAD-C | Access Doors

- TEAD18(L/R)-C** 18" Wide Access Door (left or right hinged)
- TEAD24(L/R)-C** 24" Wide Access Door (left or right hinged)
- TEAD30-C** 30" Wide Double Access Doors
- TEAD36-C** 36" Wide Double Access Doors
- TEAD42-C** 42" Wide Double Access Doors



TESD-B | Storage Drawers

- TESD132-B** 13" Wide Double Storage Drawers
- TESD133-B** 13" Wide Triple Storage Drawers
- TESD192-B** 19" Wide Double Storage Drawers
- TESD193-B** 19" Wide Triple Storage Drawers



TEDS36-B | 36" Dry Storage Cabinet

- Perfect companion to the 36", 42" or 54" built-in grill
- 3 full extension drawers behind left-hand door
- Large open storage compartment behind right-hand door
- Overall dimensions: 36" W x 20.75" H



TEDS36T-B | 36" Dry Storage Cabinet - Tall

- 34-inch tall cabinet sits just below counter height
- 4 Full extension drawers behind left-hand door
- 1 fixed shelf & 2 full extension drawer behind right-hand door
- Overall dimensions: 36" W x 34" H

Dry Storage Cabinet Features:

Every outdoor kitchen needs a place to organize and store essentials. These dry, sealed storage cabinets ensure that contents are protected from the elements. The extra deep design with fixed shelves and full extension drawers offer generous space and storage flexibility.



TEDD(2)-B | Door / Two Drawer Combo

- TEDD302-B** 30" Wide Door & Two (2) Drawer Combo
- TEDD362-B** 36" Wide Door & Two (2) Drawer Combo
- TEDD422-B** 42" Wide Door & Two (2) Drawer Combo



TEDD(3)-B | Door / Three Drawer Combo

- TEDD303-B** 30" Wide Door & Three (3) Drawer Combo
- TEDD363-B** 36" Wide Door & Three (3) Drawer Combo
- TEDD423-B** 42" Wide Door & Three (3) Drawer Combo



LP Tank / Trash Slide Kit:

- Easily mounts inside any door/drawer combo
- Allows for easy access to an LP tank or trash container
- Kit model TETS-KIT

Ventilation

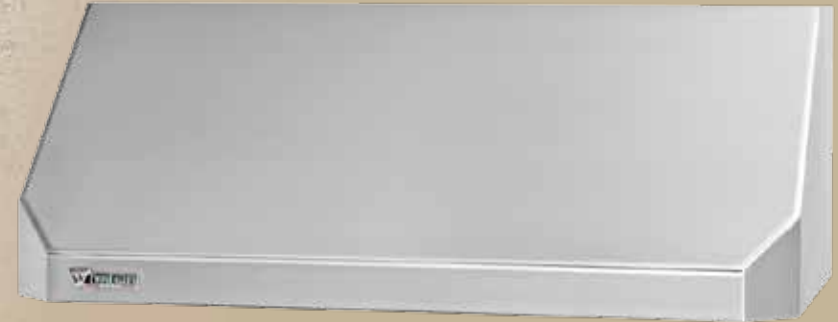

TEVH36-B
TEVH48-B
TEVH60-B

Twin Eagles Ventilation Hood

High performance ventilation hoods draw heat, steam and grease away from your cooking area. Seamless design with hi-polished accents complement the design of our grills and accessories. Available in 36", 48" and 60" sizes.

- Seamless welded with hi-polished accents
- Engineered and UL approved for outdoor use
- Easy to remove, dishwasher safe stainless steel baffle filters
- 3-speed ventilator control
- 2 halogen lamps with dual settings
- Internal and external blower motors sold separately:

TEVI-060I 600 CFM Internal Blower

TEVI-120I 1,200 CFM Internal Blower

TEVE-150E 1,500 CFM External Blower





Twin Eagles Built-in and Freestanding Vinyl Covers

Protect your investment with an all-weather Vinyl Cover. The soft interior will protect the fine stainless steel finish while the durable vinyl exterior will protect your grill from harsh weather. Available for all built-in grills and built-in accessories including: Power Burner, Single & Double Side Burner, Dine & Breakfast Club and Teppanyaki Griddle. Covers are also available for all freestanding grills, the freestanding Dine & Breakfast Club and Teppanyaki Griddle.



TECT | Charcoal Tray

Great for people that love the taste of food cooked over a charcoal flame. All stainless steel accessory with built-in ash collector for easy cleaning. It uses the existing burner to light the charcoal briquettes or lump wood charcoal.



TEGP12 | Griddle Plate

Convenient griddle surface for use on our grills and side burners. Great for grilling breakfast, fajitas, or stir fry. All stainless steel construction.

Freestanding Grills





Twin Eagles 30", 36" and 42" grills are available with integrated grill bases for a portable freestanding grill option. The grill bases beautifully match grills and accessories. Standard features include soft closing doors and self latching drawers, heavy duty casters with front brakes for easy maneuverability and locking, and fold down side shelves with tool holders. The pull-out tray inside can be used to hold a trash receptacle or LP tank. Access doors and storage drawers feature flush handle design with hi-polished accents.

Tool Holders

Both side shelves have specially designed tool holders to keep your tools handy, yet conveniently out of the way, so your side shelves may be used for other items essential to grilling.





Product Number	Compatible Products	
TEGB30-B	Compatible with any 30" built-in grill, the Dine & Breakfast Club and Teppanyaki griddle	
TEGB30SD-B	Compatible with any 30" built-in grill, the Dine & Breakfast Club and Teppanyaki griddle	
TEGB36-B	Compatible with any 36" built-in grill	
TEGB36SD-B	Compatible with any 36" built-in grill	

Product Number	Compatible Products	
TEGB42SD-B	Compatible with any 42" built-in grill	
TSGB24	Compatible with Salamangrill only	
TESB132F-B	Available for all 30", 36" and 42" Grill Bases	



GAS HEATER

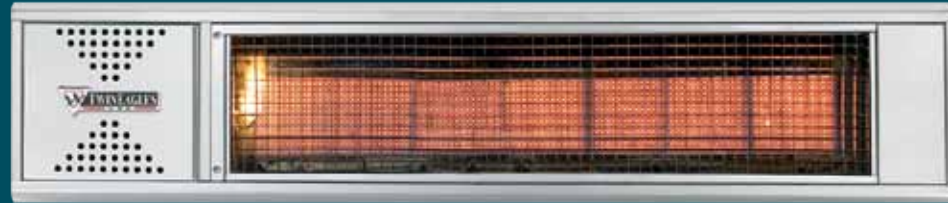
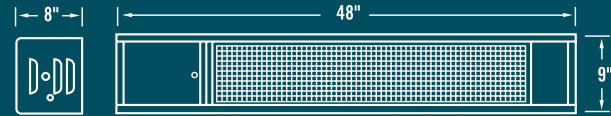

TEGH48 | 48" Outdoor Gas Infrared Heater

U.S. Patent # 8,540,509 B1

Our Radiant Gas Heater is the ultimate heat source to extend your outdoor entertaining into late evening, providing comfortable heat year round. Our 48" Infrared Heater will keep your guests warm with exceptional heat coverage, while easily controlling the heat settings from a convenient wireless remote control.

- Two heat levels: Low setting at 25,000 BTU and high setting at 37,000 BTU
- Wireless remote control (No electrical wiring required)
- Spark ignition with 100% safety pilot
- Decorative safety grill that provides shielding from wind. Wind proof up to 15 MPH
- Complete with mounting brackets and gas hose



Wireless remote control (included)



Flexible gas hose approved for NG & LP (included)



A set of stainless steel mounting brackets (included)

HEATING AREA COVERAGE

Heater must be mounted a minimum of 8 feet from floor.

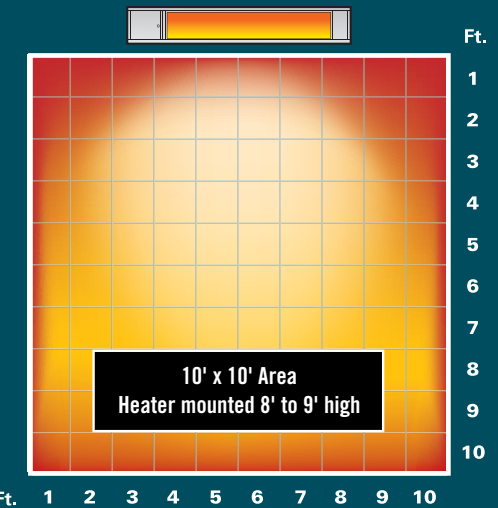

TEGH-AC | 120 VAC / 6 VDC Adapter

- Optional Accessory (Sold Separately)



ELECTRIC HEATERS



TEEH2524 | **39" Electric Radiant Heater (Indoor/Outdoor)**

Length: 39" Volts: 240
Watts: 2500 Amps: 10.4



TEEH3524 | **61" Electric Radiant Heater (Indoor/Outdoor)**

Length: 61" Volts: 240
Watts: 3500 Amps: 14.6

39" & 61" Electric Radiant Heaters (Indoor/Outdoor)

Our Electric Heaters are the perfect addition to your backyard, patio, or deck. Extend your outdoor entertaining by maintaining a warm, comfortable atmosphere for you and your guests well into a cool evening. The heaters are suitable for both indoor and outdoor use and can be installed at lower mounting heights (6-8 ft.), helping to maximize the heat where you need it the most, especially in coastal areas.

- Energy Efficient — 90% of the input energy is converted directly to radiant heat.
- The parabolic reflector is made of a special corrosive resistant alloy, an important feature for humid climates or windy areas.
- Swivel mounting brackets allow 6" of clearance behind heater
- UL Approved



Incremental Control

Wall mountable incremental control for easily regulated heat settings. (included with heaters.)

HEATING AREA COVERAGE

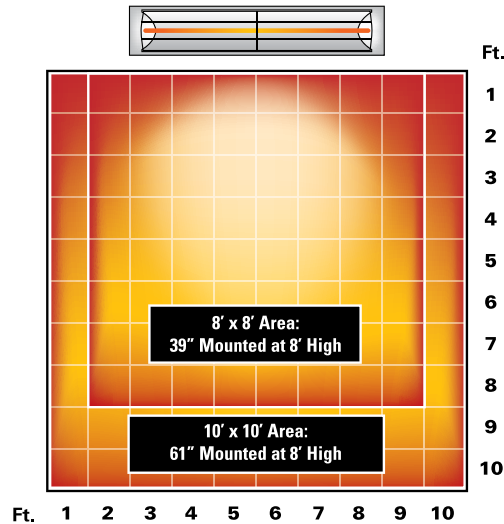

CUTOUT DIMENSIONS

COUNTERTOP NOTCH REQUIREMENT

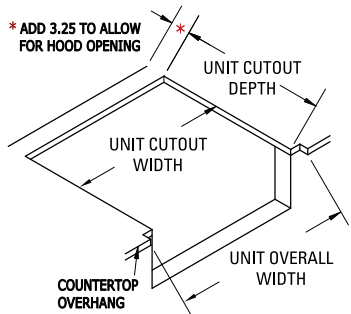

Allow minimum of 2.50" clearance from the grill's rear edge (3.25" from cutout) to the backsplash to allow hood to fully open.

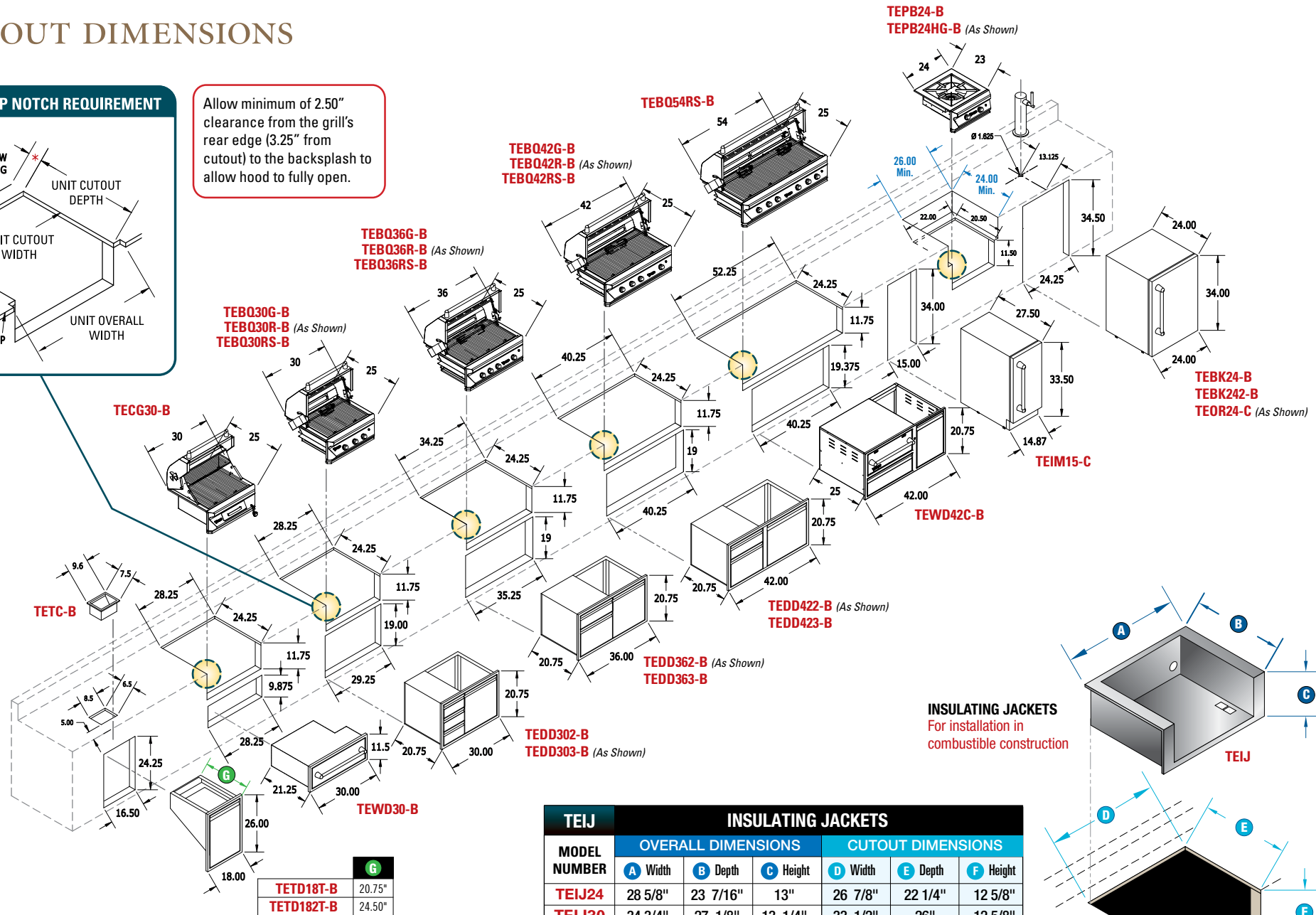

TEBD18T-B	20.75"
TEBD182T-B	24.50"

INSULATING JACKETS
For installation in combustible construction

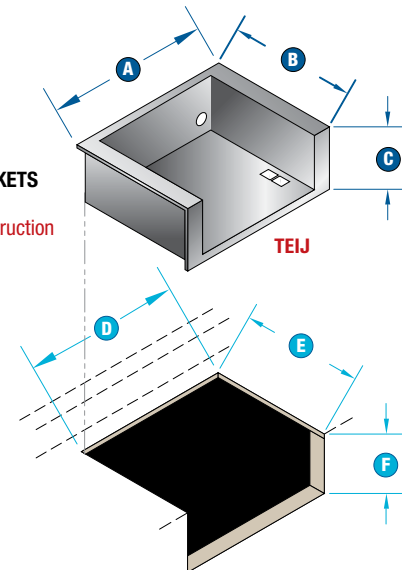

TEIJ MODEL NUMBER	OVERALL DIMENSIONS			CUTOUT DIMENSIONS		
	A Width	B Depth	C Height	D Width	E Depth	F Height
TEIJ24	28 5/8"	23 7/16"	13"	26 7/8"	22 1/4"	12 5/8"
TEIJ30	34 3/4"	27 1/8"	13 1/4"	33 1/2"	26"	12 5/8"
TEIJ36	40 3/4"	27 1/8"	13 1/4"	39 1/2"	26"	12 5/8"
TEIJ42	46 3/4"	27 1/8"	13 1/4"	45 1/2"	26"	12 5/8"
TEIJ54	58 3/4"	27 1/8"	13 1/4"	57 1/2"	26"	12 5/8"

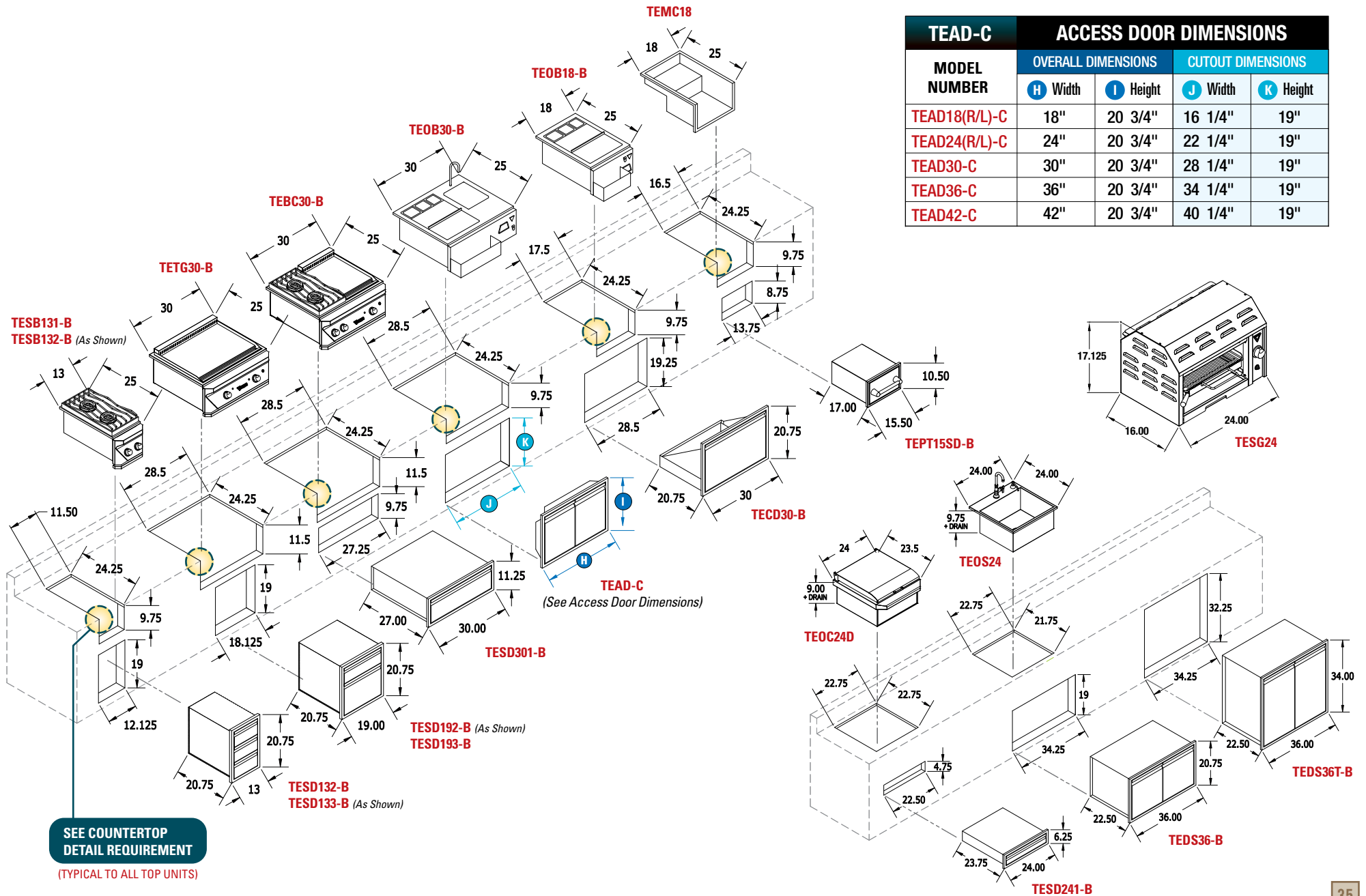



Creative design, innovative engineering, precision manufacturing, and impeccable quality control — all under one roof!

Twin Eagles develops, from design prototyping to testing to final production, gas grills and outdoor kitchen accessories at their state-of-the-art company owned facility in Cerritos, California.

The Twin Eagles family consists of passionate, highly trained designers, engineers and skilled craftsmen bringing you exquisite products and clearly...

*Defining the Art of
Outdoor Cooking.*



MADE IN THE U.S.A.

TWIN EAGLES, INC.®

13259 East 166th Street, Cerritos, CA 90703

(800) 789-2206

www.TwinEaglesBBQ.com

© 2014 Twin Eagles, Inc. All rights reserved. P/N 18561K 01/14
For the constant advancement of our products, Twin Eagles® reserves the right to change the specifications, designs, and materials of the products without prior notification.